

**Use e manutenzione
Emploi et entretien
Gebrauch und Instandhaltung
Use and maintenance
Uso y manutención
Uso e manutenção**

epoca

**Macchina per caffè
Machine à café
Kaffeemaschinen
Coffee machine
Máquina para café
Máquina para café**

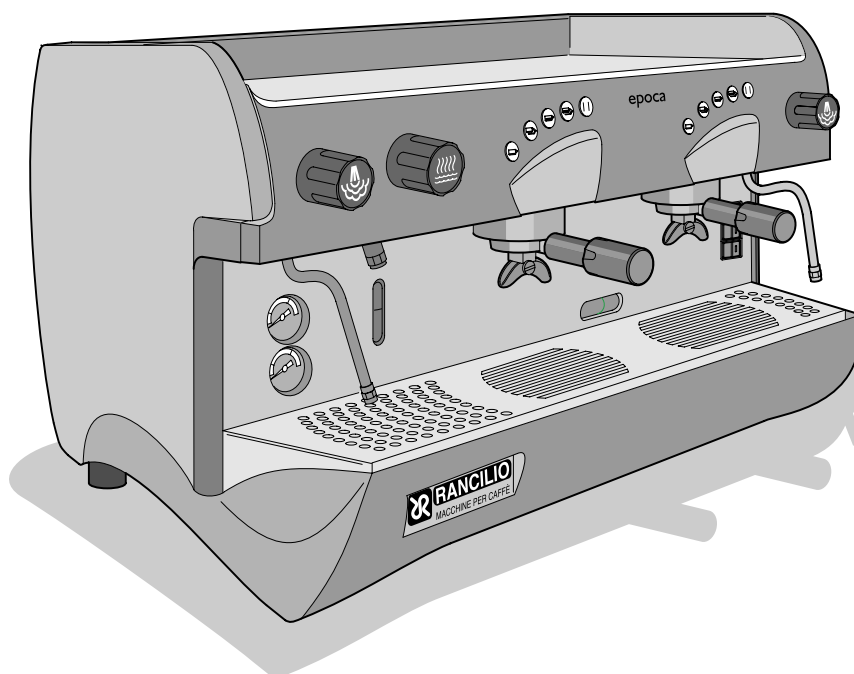

- DE
- CD
- S

RANCILIO
macchine per caffè

IT

**Gentile cliente,
grazie per averci accordato la Sua fiducia.**

Siamo sicuri che il prodotto che Lei ha acquistato risponderà in pieno alle Sue aspettative, come tutti gli altri articoli della produzione RANCILIO. Il prodotto che Lei si accinge ad usare è il risultato di approfonditi studi e meticolose sperimentazioni fatte dalla RANCILIO per offrirLe quanto di più funzionale, sicuro ed apprezzabile, anche sotto il profilo del design, si possa trovare sul mercato. Il libretto di istruzioni per il corretto uso e manutenzione della macchina La aiuterà a sfruttare al meglio le sue elevatissime possibilità e prestazioni.

Con l'augurio di poterLa sempre annoverare tra i nostri clienti, Le auguriamo una buona lettura.

FR

**Cher Client,
Nous Vous remercions pour Votre confiance.**

Nous sommes certains que le produit que Vous avez acheté correspondra entièrement à Vos désirs, comme du reste tous les articles de la production RANCILIO. Le produit que Vous allez employer est le résultat d'études approfondies et de méticuleux essais effectués par RANCILIO afin de pouvoir Vous offrir le produit le plus fonctionnel, le plus sûr et le plus remarquable, également du point de vue design, que l'on puisse trouver sur le marché. Le petit livre d'instructions pour l'emploi correct et l'entretien de la machine Vous aidera à tirer le maximum de ses grandes possibilités et performances. Nous sommes certains que nos explications sont claires et espérons, cher client, mériter Votre fidélité.

DE

**Sehr geehrte Kundin/sehr geehrter Kunde,
Zuerst möchten wir Ihnen für das uns entgegengebrachte Vertrauen danken.**

Wir hoffen, dass das von Ihnen gekaufte Produkt Ihren Erwartungen in jeder Hinsicht entsprechen wird- wie übrigens auch all unsere anderen Erzeugnisse. Das Produkt das Sie in Gebrauch nehmen werden, ist das Resultat von sorgfältigen von RANCILIO Untersuchungen und Tests, um Ihnen in Bezug auf Funktionalität, Sicherheit, Leitungsfähigkeit sowie Design ein Produkt anbieten zu können, das das Beste auf Markt befindliche ist. Das Büchlein mit den Anweisungen für eine korrekte Bedienung und Wartung der Maschine wird Ihnen behilflich sein, das Beste aus Ihrem Gerät zu machen. Wir hoffen, dass unsere Erklärungen verständlich sind und dass Sie auch in Zukunft zu unseren Kunden zählen dürfen.

Mit freundlichen Grüßen.

EN

**Dear Customer,
First of all, thank you choosing RANCILIO.**

We are confident that the product you have purchased will come up to all your expectations-just as all our other products are designed to do. The product that you are about to use is the outcome of painstaking research and tests. The Rancilio's consistency assures quite sure that the equipment we have supplied you with, is the most functional, safe and satisfactory of its kind to be found on the market, as regards both its design and its efficiency. The booklet of instructions for its correct use and maintenance will help you to get the best possible service out of your machine. We trust you will find our explanations clear and we may continue, in the future, to count you among our esteemed customers.

ES

**Muy estimado cliente:
muchas gracias por habernos acordado Su confianza.**

Estamos seguros que el producto que Ud. ha adquirido responderá seguramente a Sus esperanzas, así como es por todos los demás artículos RANCILIO fabrica. El producto que Ud. se apresta a utilizar es el resultado de particulares estudios y pruebas meticolosas hechas por la firma RANCILIO para ofrecerle un producto funcional, seguro y apreciable, también por lo que se refiere al design, seguramente uno de los mejores que Ud. pueda encontrar en comercio. El manual de instrucciones para utilizar correctamente y efectuar la manutención de la máquina, la ayudará a disfrutar a lo máximo las elevadas posibilidades y prestaciones de la misma. Mientras confiamos que Ud. siga siendo siempre Cliente nuestro, le deseamos una provechosa lectura.

PT

**Prezado Cliente,
Obrigado por nos ter dado a sua confiança.**

Temos certeza que o produto que Você comprou responderá totalmente as suas expectativas, como todos os outros artigos da produção RANCILIO. O produto que Você está para usar é o resultado de estudos profundos e experiências meticolosas feitas pela RANCILIO, para oferece-lhe quanto de mais funcional, seguro e considerável, também sob o perfil do design, que se possa encontrar no mercado. O manual de instruções para o uso correto e manutenção da máquina lhe ajudará a desfrutar ao máximo as suas elevadíssimas possibilidades e desempenhos.

Com o desejo de poder tê-lo sempre entre os nossos clientes, desejamo-lhe uma boa leitura.

EUROPEAN UNION ONLY

IT **Trattamento dei rifiuti delle apparecchiature elettriche ed elettroniche.** Smaltire il prodotto seguendo le norme vigenti relative allo smaltimento differenziato presso centri di raccolta dedicati.

Non trattare come semplice rifiuto urbano.

Per qualsiasi informazione necessaria contattare il costruttore all'indirizzo indicato nel libretto istruzioni.

Il prodotto risponde ai requisiti richiesti dalle nuove direttive introdotte a tutela dell'ambiente e che deve essere smaltito in modo appropriato al termine del suo ciclo di vita.



EN **Treatment of waste from electric/electronic equipment**
Dispose of the product in accordance with current regulations concerning differentiated waste disposal in dedicated waste disposal areas.

Do not treat as simple urban waste.

For any information please contact the manufacturer at the address specified in the user manual.

The product complies with the requirements of the new directives introduced for the environmental safeguard and must be disposed of appropriately at the end of its life cycle.



FR **Traitement des ordures des équipements électriques et électroniques**
Écouler le produit conformément aux normes en vigueur concernant l'écoulement différencié auprès de centres de récolte dédiés.

Ne pas traiter comme simples ordures urbaines. Pour toute information nécessaire contacter le constructeur à l'adresse indiquée dans le manuel d'emploi.

Le produit est conforme aux caractéristiques requises par les nouvelles directives introduites pour la sauvegarde de l'environnement et doit être écoulé de façon appropriée à la fin de son cycle de vie.



DE **Entsorgung von elektrischen und elektronischen Geräten**
Das ist Produkt gemäß den geltenden Normen für die Mülltrennung bei den zuständigen Sammelzentren zu entsorgen.

Nicht wie normalen Müll behandeln.

Weitere Informationen sind beim Hersteller unter der in der Gebrauchsanleitung angegebenen Adresse zu erhalten.

Das Produkt entspricht den Erfordernissen den neuen Richtlinien über den Umweltschutz, und muss an seinem Lebensende entsprechend entsorgt werden.



ES **Tratamiento de los desechos de los equipos eléctricos y electrónicos**
Eliminar el producto en los centros de recolección especializados, siguiendo las normas vigentes relativas a la eliminación diferenciada.

No tratar como simple desecho urbano.

Para cualquier información necesaria, contacten al fabricante en la dirección indicada en el manual de instrucciones.

El producto responde a los requisitos demandados en las nuevas directivas introducidas para la protección del ambiente y debe ser eliminado de manera apropiada al final de su ciclo de vida.



PT **Tratamento do lixo dos aparelhos elétricos e eletrônicos**
Jogar o produtos seguindo as normas em vigor relativas à coleta diferenciada em centros de coleta apropriados.

Não tratar como simples lixo urbano.

Para qualquer informação necessária contactar o construtor no endereço indicado no manual de instruções.

O produto responde aos requisitos exigidos pelas novas diretrizes introduzidas para tutelar o ambiente e deve ser sucadato em modo apropriado ao final do seu ciclo de vida.



NL **Afvalbehandeling van de elektrische en elektronische apparatuur**
Verwerk het product volgens de geldende normen m.b.t. de gescheiden afval bij de voorbestemde vuilniscentrums.

Behandel het product niet als eenvoudig stadsvuil.

Neem contact op met de constructeur op het aangegeven adres in deze handleiding voor nadere informatie.

Het product beantwoordt aan de door de nieuwe richtlijnen verlangde vereisten ingevoerd ter bescherming van het milieu en moet op passende wijze op het einde van zijn levenscyclus worden verwerkt.



DK **Behandling af affald fra elektrisk/elektronisk udstyr**
Bortskaf produktet i overensstemmelse med nuværende reguleringer vedr. forskellige affaldsprodukter på deponeringssteder dedikeret til affald.

Må ikke behandles som alm. byaffald.

Kontakt producenten på den specificerede adresse i brugerhåndbogen for yderligere oplysninger.

Produktet er i overensstemmelse med de nye direktiver, introduceret for miljøforanstaltningen og skal bortskaffes på behørig vis ved slutningen af dens livscyklus.



SE **Avfallshantering av elektriska och elektroniska apparater**
Nedskrota produkten genom att följa gällande normer för differentierad sanering på seriösa uppsamlingsställen.

Behandla det inte som vanligt tätortsavfall.

Vid behov av ytterligare information, var vänlig ta kontakt med tillverkaren på den adress som anges i bruksanvisningen.

Produkten motsvarar de krav som ställs i de nya miljödirektiverna och den måste nedskrotas på ett lämpligt sätt i slutet av sin livscykel.



NO **Behandling av avfall fra elektrisk/elektronisk utstyr**
Produktet skal avhendes i samsvar med gjeldende forskrifter angående differensiert avfallsavhending på dediserte avfallsavhendingsområder.

Det må ikke behandles som vanlig byavfall.

For videre opplysninger vennligst kontakt fabrikanten på adressen som er angitt i bruksanvisningen.

Produktet etterkommer kravene i de nye miljødirektivene og skal avhendes på en passende måte etter avsluttet bruk.



FI **Sähköisten ja elektronisten laitteiden jätteiden käsittely**

Hävittä tuote noudattaen seuraavia voimassa olevia lajitellun jätteen käsittelyä koskevia määräyksiä asianmukaiseen jätteenkäsittelylaitokseen.

Älä käsittele sitä tavallisena kaupunkijätteenä.

Mitä tahansa tietoja varten ota yhteyttä valmistajaan ohjekirjassa olevaan osoitteeseen.

Tuote on uusien ympäristöä suojaavien direktiivien vaatimusten mukainen ja se tulee hävittää asianmukaisella tavalla sen käyttöiän päätyttyä.



GR **Επεξεργασία απορριμάτων των ηλεκτρικών/ηλεκτρονικών συσκευών**
Διαθέστε το προϊόν ακολουθώντας τις ισχύουσες νομοθεσίες περί διαφορετικής επεξεργασίας των απορριμάτων σε ειδικές περιοχές διάθεσης των απορριμάτων. Μη τα διαχειρίζεστε ως απλά αστικά απόβλητα.

Για οποιαδήποτε πληροφορία, επικοινωνήστε με τον κατασκευαστή στη διεύθυνση που αναφέρεται στο εγχειρίδιο των οδηγιών.

Το προϊόν τηρεί τις προϋποθέσεις που προβλέπουν οι νέες οδηγίες αναφορικά με την προστασία του περιβάλλοντος και πρέπει να διατίθεται με τον κατάλληλο τρόπο μετά το τέλος της χρήσης του.



SK **Zaobchádzanie s odpadmi z elektrických / elektronických zariadení**
Výrobok likvidujte podľa súčasných predpisov o likvidácii triedeného odpadu na k tomu určených skládkach.

Nezaobchádzajte s ním ako s bežným komunálnym odpadom.

Ak potrebujete akékoľvek informácie, kontaktujte, prosím, výrobcu na adrese uvedenej v návode na použitie.

Výrobok zodpovedá požiadavkám nových smerníc zavedených pre ochranu životného prostredia a zlikvidovať sa na konci svojej životnosti musí príslušným spôsobom.



HU **Az elektromos és elektronikai készülékek hulladékkezelése**
A termék az erre a célra kijelölt gyűjtőhelyekre adja le követve a szelektív hulladékgyűjtéssel kapcsolatos jelenlegi jogszabályokat.

Ne kezelje közönséges városi hulladékként.

Bármennyi információért forduljon a gyártóhoz, melynek címét a használati útmutatóban találja.

A termék megfelel a környezet védelme érdekében újonnan bevezetett irányelvek követelményeinek és ennek megfelelően kell kezelni az élettartamának végeztével.



CZ **Zacházení s odpady z elektrických / elektronických zařízení**
Výrobek likvidujte podle současných předpisů o likvidaci tříděného odpadu na k tomu určených skládkách.

Nezacházejte s ním jako s běžným obecním odpadem.

Potřebujete-li jakékoli informace, kontaktujte prosím výrobce na adrese uvedené v návodu pro použití.

Výrobek odpovídá požadavkům nových směrnic zavedených pro ochranu životního prostředí a zlikvidovat se na konci své životnosti musí příslušným způsobem.



ET **Elektri- ja elektronseadmete jäätmete töötlemine**
Tootest lahtisaamist peab läbi viima vastavalt käibivatele eeskirjale, mis käsitlevad jäätmetest eristatud lahtisaamist selleks mõeldud jäätmetest lahtisaamise alades.

Mitte töödelda nagu tavalisi majapidamisjäätmeid.

Mistahes informatsiooni saamiseks pöörduge palun tootja poole aadressil, mis on märgitud kasutaja käsiraamatus.

Toode vastab uutele nõuetele, mis on esitletud keskkonna kaitsmiseks ja sellest peab reeglipäraselt lahti saama selle elutsükli lõpus.



LT **Kur išmesti elektros \ elektroninės įrangos atliekas.**
Šalinikite įrangos atliekas atitinkamai esamų taisyklių, kurios liečia tokios rūšies atliekas apie specialias atliekų kaupimo vietas.

Nemeskite atliekas į paprastus miesto šiukšlių konteinerius. Papildomos informacijos kreipkitės į gamintoją nurodytu vartotojo instrukcijoje adresu.

Šis produktas atitinka įvestos ekologiniam saugumui naujos direktyvos reikalavimus ir turi būti sunaikintas pasibaigus jo atitiktis terminui.



SL **Obdelava odpadkov električnih in elektronskih naprav**
Odlaganje izdelkov je potrebno vršiti v skladu z veljavnimi predpisi v zvezi z selektivnim odlaganjem odpadkov v centrih za zbiranje odpadkov ki so temu namenjeni. Ne odlagajte ga kot običajne smeti.

Za kakršnokoli informacijo kontaktirajte proizvajalca na naslovu, ki je naveden v priložnici z navodili.

Izdelek odgovarja zahtevam novih smernic, ki so uvedene zaradi zaščite življenjske sredine in mora biti odložen na ustrezen način po koncu življenjske dobe.



PL **Postępowanie z odpadami pochodzącymi z urządzeń elektrycznych/elektronicznych**
Produkt musi zostać poddany utylizacji zgodnie z obowiązującymi przepisami dotyczącymi segregowania odpadów w specjalnie do tego wyznaczonych miejscach. Nie wyrzucać razem ze zwykłymi odpadami miejskimi.

W celu uzyskania jakichkolwiek informacji proszę skontaktować się z producentem pod adresem podanym w instrukcji obsługi dla użytkownika.

Ten produkt odpowiada wymogom zawartym w nowych dyrektywach wprowadzonych w celu ochrony środowiska i po zakończeniu cyklu eksploatacji musi zostać zutilizowany we właściwy sposób.



LV **Kā utilizēt elektrisko/elektronisko iekārtu atkritumus**
Iekārtu atkritumus nepieciešams utilizēt atbilstoši spēkā esošajiem noteikumiem, kuri reglamentē dažādu veidu atkritumu utilizēšanu tikai speciāliem atkritumu konteineros. Nemetiet šos atkritumus parastajos kopējos pilsētas atkritumu.

Lai saņemtu jebkuru informāciju, griežieties pie ražotāja, kura adrese uzrādīta ekspluatācijas instrukcijā.

Dotais produkts atbilst jaunās direktīvas prasībām, kura attiecas uz ekoloģisko drošību, un tas ir atbilstoši kārtībā utilizējams pēc tā, kad nobeigsis tā derīguma termiņš.





macchine per caffè
20010 Villastanza di Parabiago (MI)
Viale della Repubblica 40

**DICHIARAZIONE DI CONFORMITA' CE - DECLARATION DE CONFORMITE CE
EG-KONFORMITÄTSEKTLÄRUNG - EC DECLARATION OF CONFORMITY
DECLARACIÓN DE CONFORMIDAD CE - DECLARAÇÃO DE CONFORMIDADE CE**

Noi **RANCILIO** Macchine per caffè S.p.A.

Dichiariamo sotto la nostra responsabilità che il prodotto: **Macchina per caffè per uso professionale**
Déclarons, sous notre responsabilité, que le produit : **Machine à café d'utilisation professionnel**
Wir erklären auf unsere Verantwortung, daß das Produkt: **Kaffeemaschine für Beruflichgebrauch**
Declare under our responsibility that the product: **Espresso coffee makers for commercial use**
Declaramos bajo nuestra responsabilidad que el producto: **Máquina para café de uso profesional**
Declaramos sob a nossa responsabilidade que o produto: **Máquina para café para uso profissional**

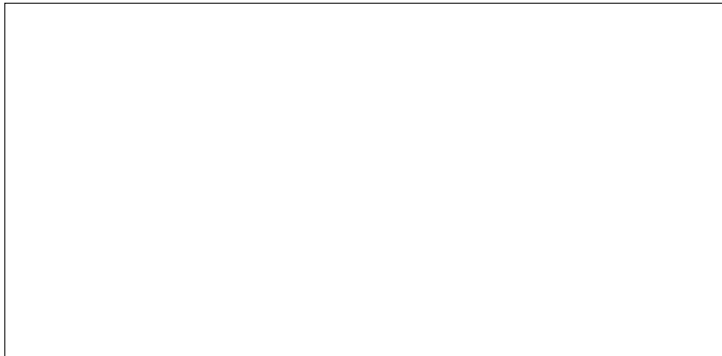

al quale è riferita questa Dichiarazione, secondo quanto prescritto dalle direttive specifiche:
à laquelle se réfère cette déclaration, selon les prescriptions des directives spécifiques.
auf das sich diese Erklärung bezieht, Entsprechend der Vorschriften der spezifischen Richtlinien.
to which this declaration relates is, according to the provisions of the specific directives:
al cual se refiere esta Declaración, de acuerdo con lo prescrito por las específicas directivas:
ao qual se refere esta Declaração, segundo quanto prescrito pelas específicas diretrizes:

98/37/CE

Direttiva macchina - Direttiva machine - Richtlinie Maschine - Makers directive - Directiva máquina - Diretriz da máquina:

73/23/CEE, 93/68/CEE

Direttiva Bassa Tensione - Direttiva Basse Tension - Niederspannungsrichtlinie - Low Voltage Directive - Directiva Baja Tensión - Diretriz Baixa Tensão:

89/336/CEE, 93/68/CEE, 92/31/CEE

Direttiva EMC - Direttiva EMC - Richtlinie EMC - EMC Directive - Directiva EMC - Diretriz EMC

97/23/CE

Direttiva attrezzatura a pressione (PED)-Directive sur les appareillages sous pression (PED)-Richtlinie für unter Druck stehende Geräte (PED) Pressure device directive (PED) - Directiva equipos de presión (PED) - Diretriz aparelhagem de pressão (PED)

è conforme alle seguenti norme: - conforme aux normes suivantes :
In Übereinstimmung mit den folgenden Normen: - it complies with the following norms:
es conforme a las siguientes normas: - É conforme as seguintes normas:

EN 60335-1, EN 60335-2-75, EN 55014-1, EN 55014-2, EN 61000-3, EN 61000-4, EN 50366

Norme EN armonizzate - Normes EN harmonisées - Harmonisierte EN-Norme - Harmonized EN norms - Normas EN armonizadas - Normes EN Harmonia

Il presidente - The president

Sig. Giorgio Rancilio

La presente dichiarazione perde la sua validità se la macchina viene modificata senza la nostra espressa autorizzazione.
La présente déclaration perd sa validité dès lors que la machine est modifiée sans notre expresse autorisation.
Die vorliegende Erklärung verliert ihre Gültigkeit, wenn die Maschine ohne unsere ausdrückliche Genehmigung verändert wird.
The present declaration will become invalid should the machine be modified without our specific authorization.
La presente declaración pierde su validez si la máquina es modificada sin nuestra expresa autorización.
A presente declaração perde a validade se a máquina é modificada sem a nossa expressa autorização.

Descrizione attrezzatura a pressione-Description de l'appareillage sous pression-Beschreibung der unter Druck stehenden Geräte-
 Pressure device description-Descripción de los equipos de presión - Descrição dos equipamentos de pressão

| | Pressione - Pression Druck - Pressure Presión - Pressão | Temperatura - Température Temperatur - Temperature Temperatura - Temperatura | Fluido - Fluide Flüssig - Fluid Fluido - Fluido | Capacità It-Capacité It-Fähigkeit It- Capacity It-Potencia It- Potência it | |
|--|---|--|--|---|--|
| Caldaia - Chaudière Kessel - Boiler Caldera - Caldeira | 0,18/1,8 Mpa/bar | 131,2 C° | Acqua/Vapore - Eau/Vapeur Wasser/Dampf - Water/Steam Água/Vapor - Água/Vapor | 2 gr. 11 | |
| | Pressione - Pression Druck - Pressure Presión - Pressão | Temperatura - Température Temperatur - Temperature Temperatura - Temperatura | Fluido - Fluide Flüssig - Fluid Fluido - Fluido | Capacità-Capacité Fähigkeit -Capacity Potencia-Potência | Numero scambiatore -Numéro de l'échangeur Nummer des Austauschers- Exchanger number-Número intercambiador Número Intercambiador |
| Scambiatore -Echangeur Austauscher -Exchanger Intercambiador Intercambiador | 1.2/12 Mpa/bar | 131,2 C° | Acqua - Eau Wasser - Water Água - Água | 0.35 l | 2 gr. 2 |

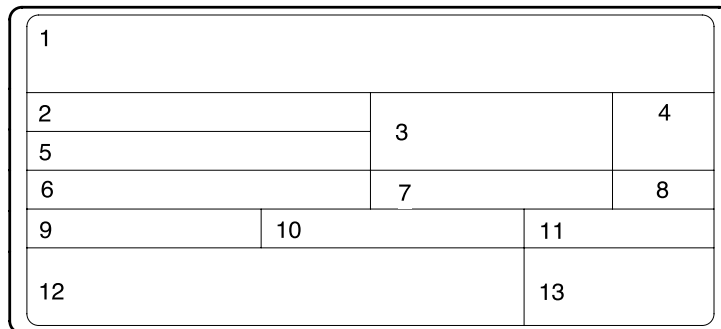

Fig. 1

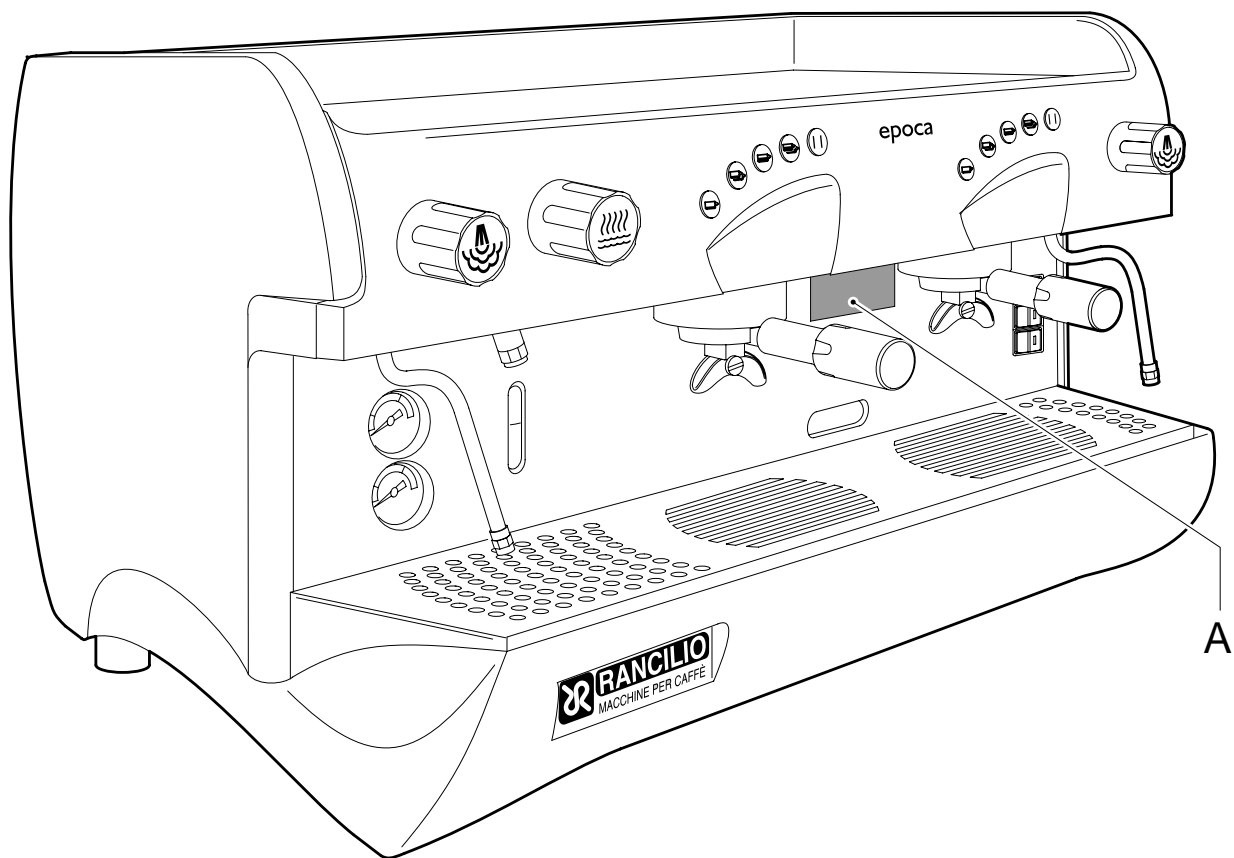
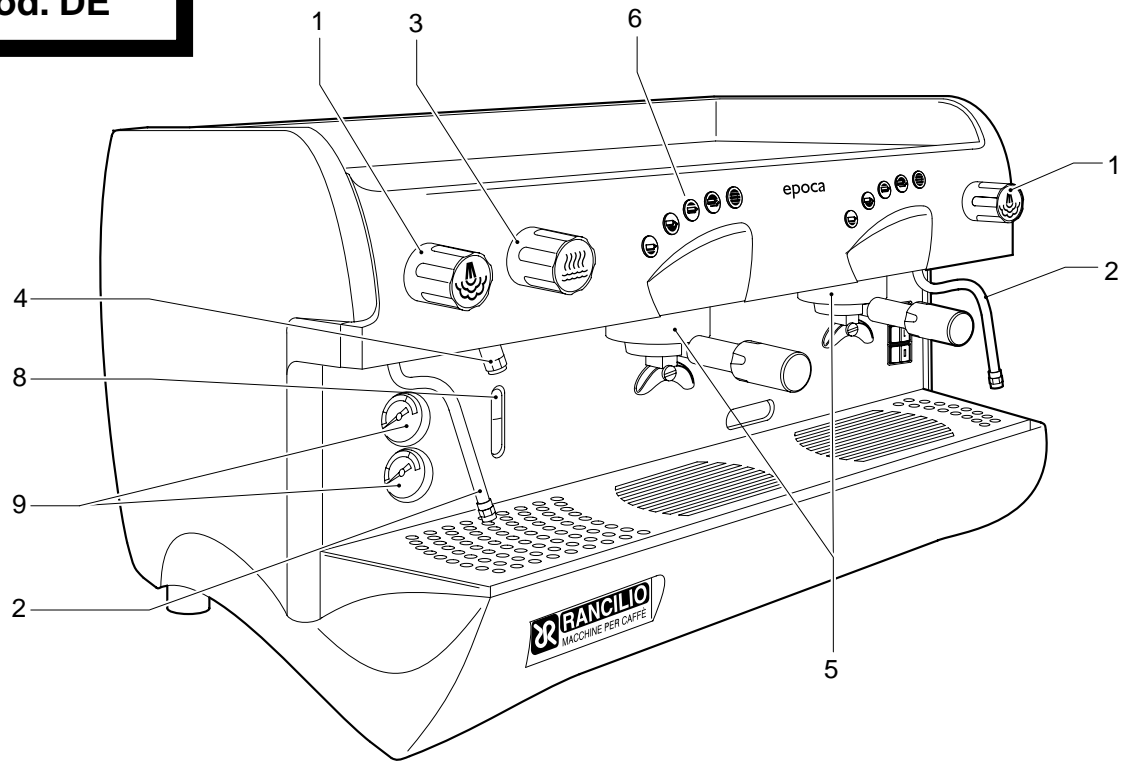

Fig. 2

mod. DE



mod. CD

mod. S

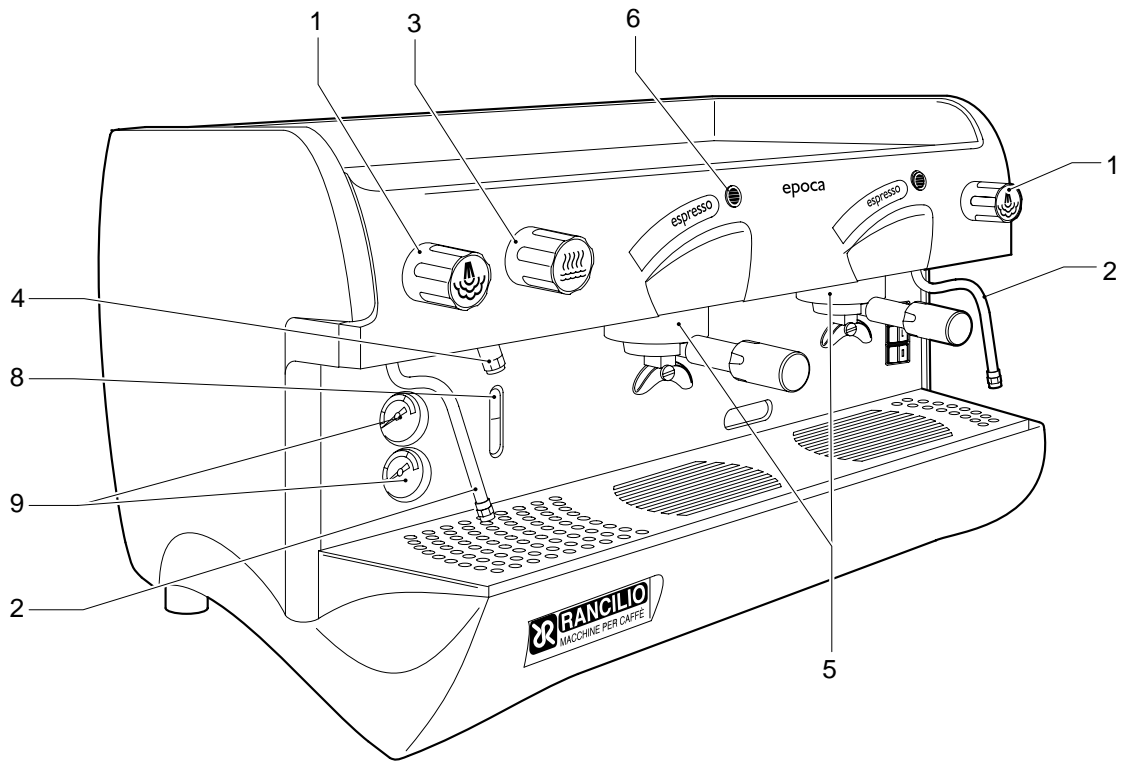
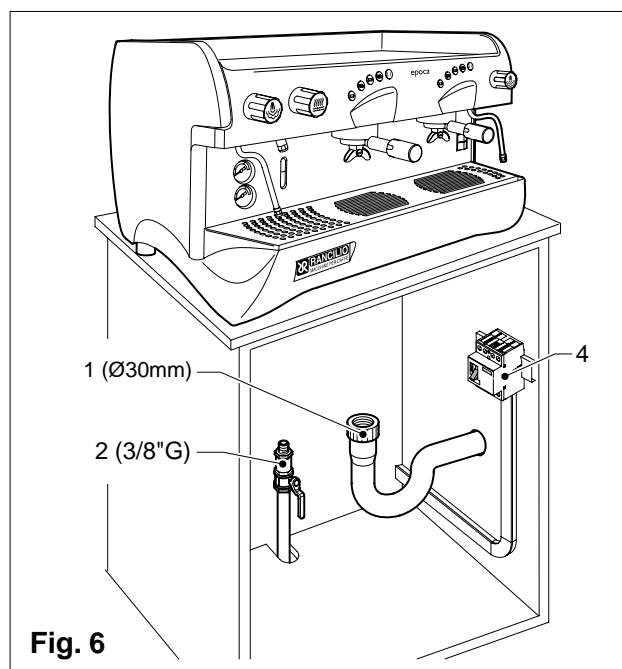
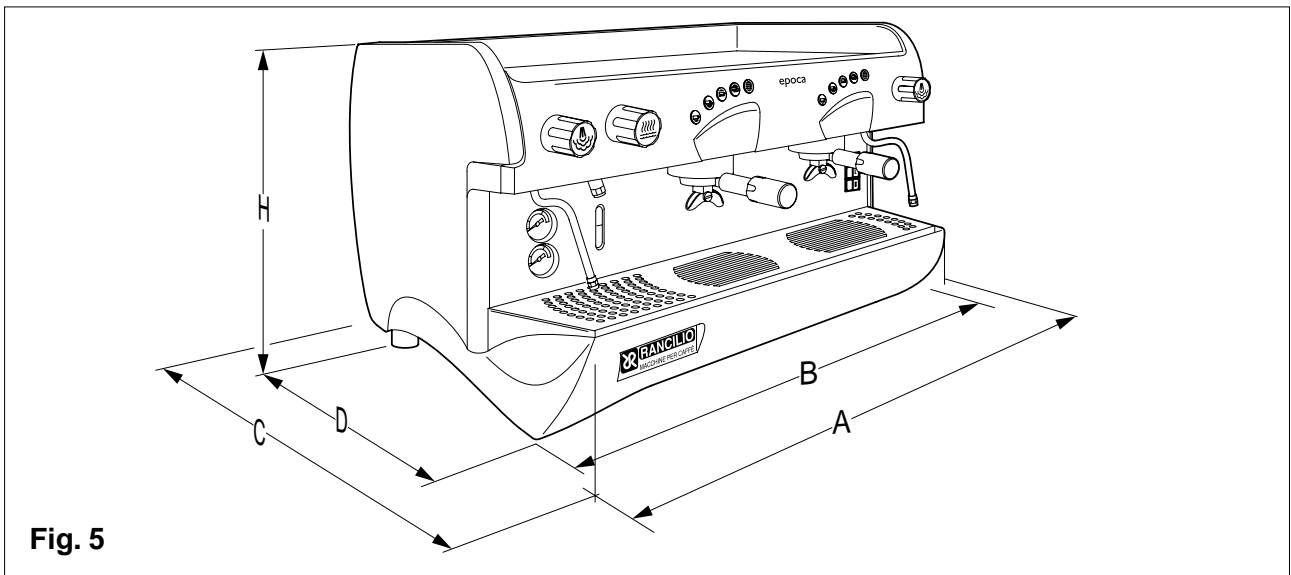
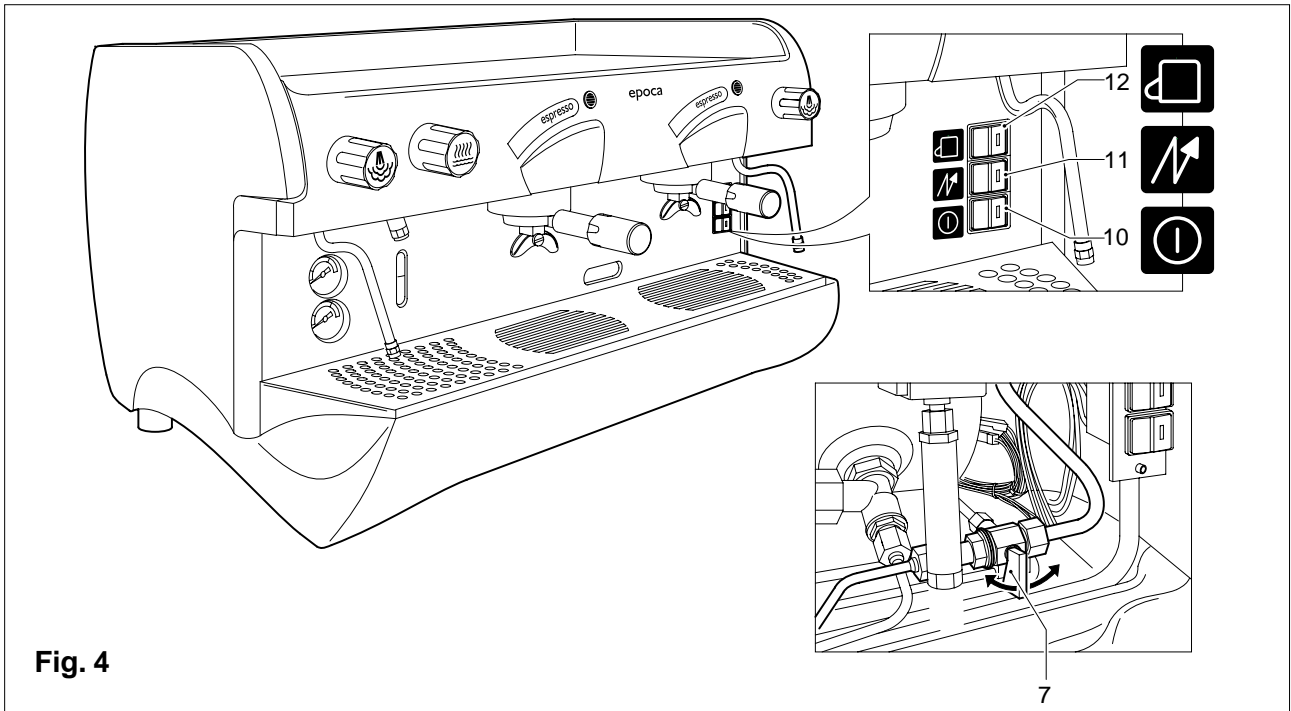
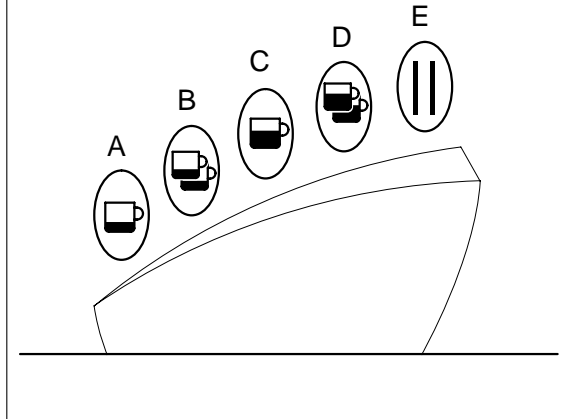

Fig. 3



mod. DE

5



mod. CD - S

3 - 4

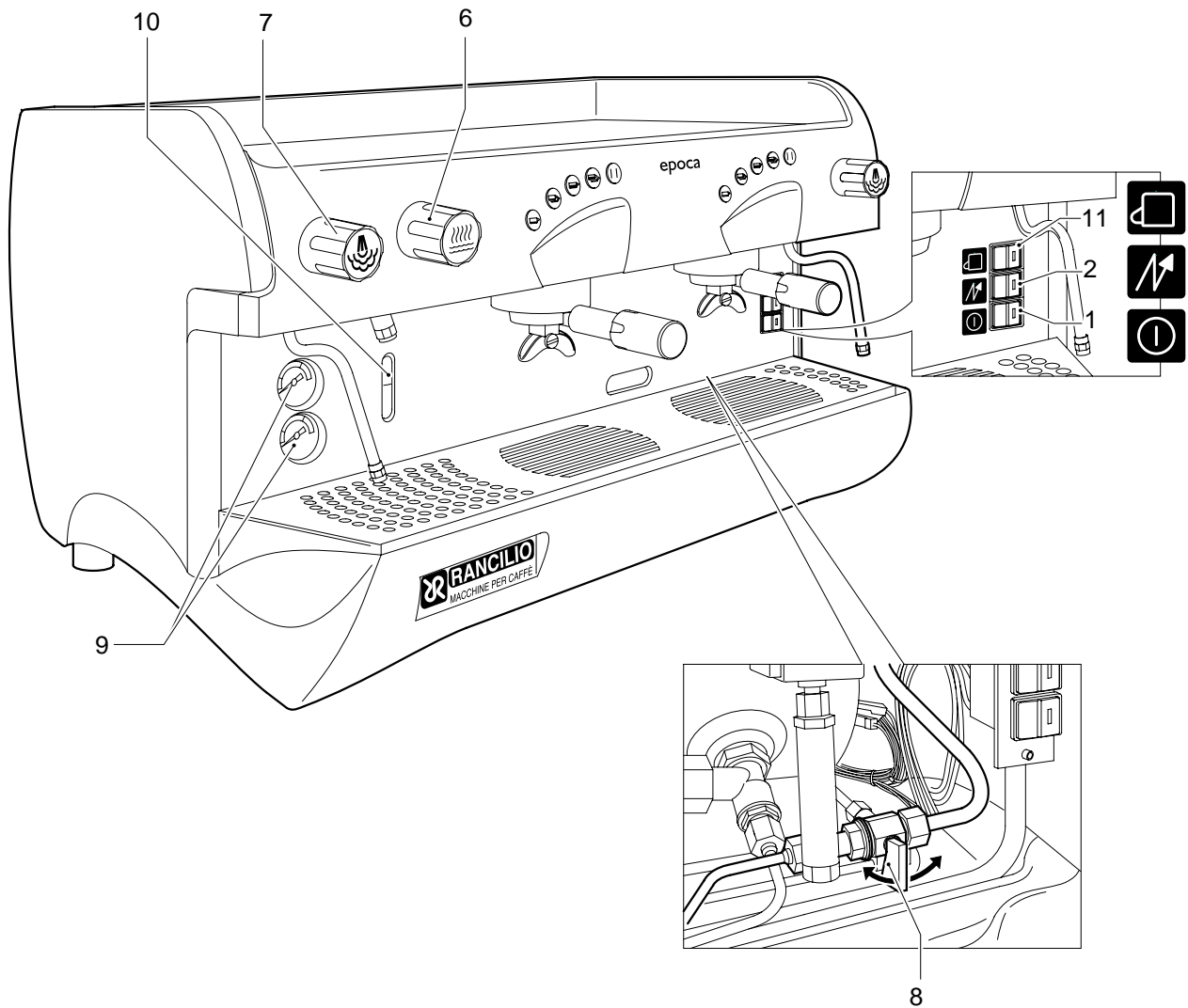
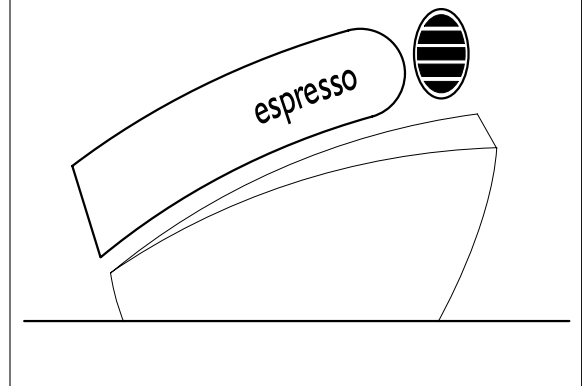
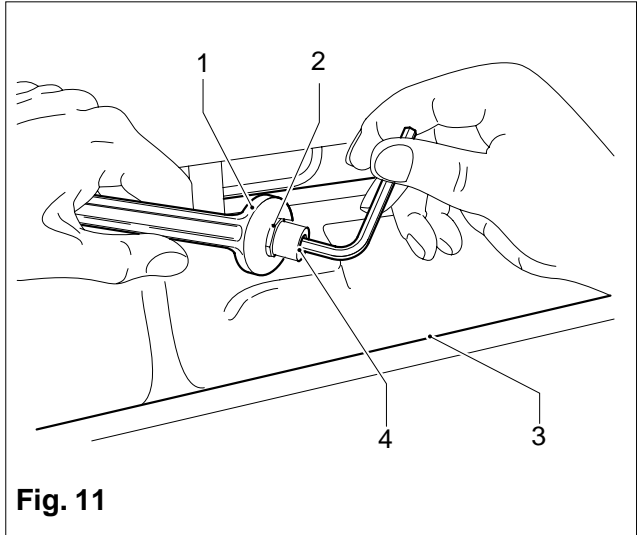
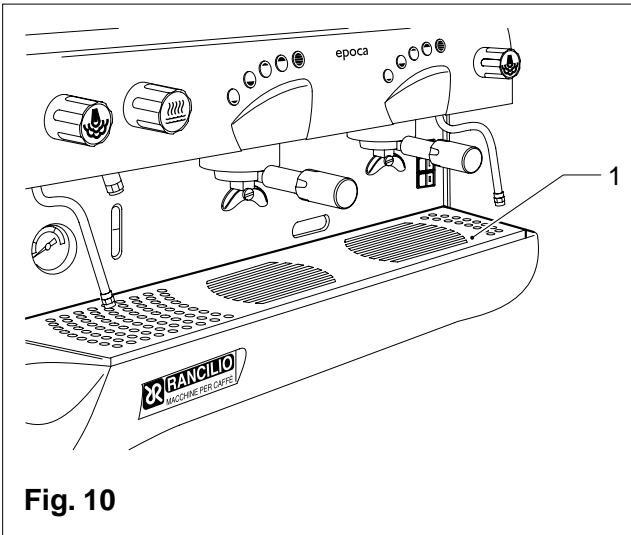
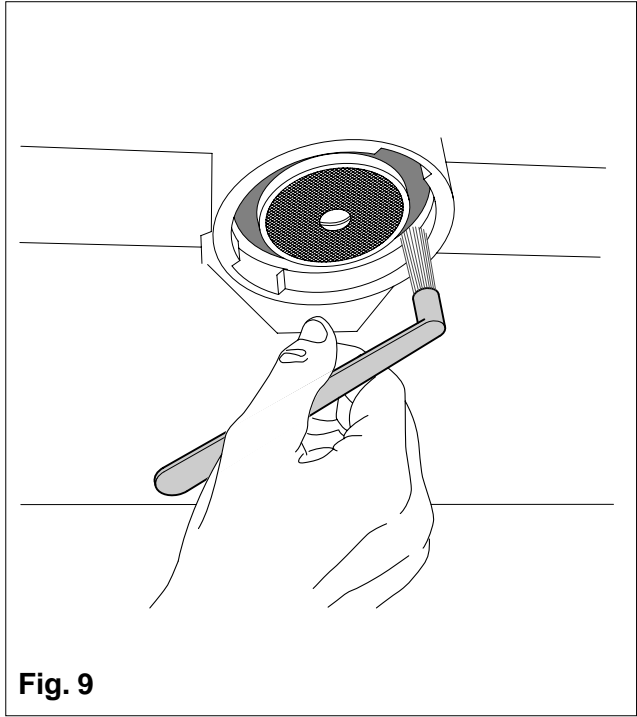
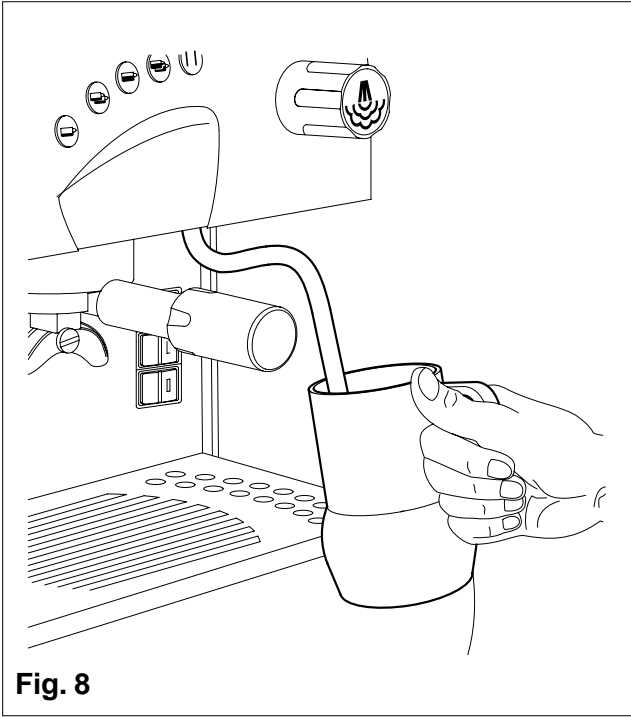

Fig. 7



| | | |
|----|-----------|--------|
| IT | ITALIANO | 12 -21 |
| FR | FRANCAIS | 22-31 |
| DE | DEUTSCH | 32-41 |
| EN | ENGLISH | 42-51 |
| ES | ESPAÑOL | 52-61 |
| PT | PORTUGUÊS | 62-71 |

| | |
|---|--------------|
| SCHEMI ELETTRICI SCHEMAS ELECTRIQUES SCHALTPLANE WIRING DIAGRAMS ESQUEMAS ELECTRICOS ESQUEMAS ELÉTRICOS | 72-78 |
|---|--------------|

| | |
|---|--------------|
| SCHEMI IDRAULICI SCHÉMAS HYDRAULIQUES HYDRAULIKPLÄNE HYDRAULIC DIAGRAMS ESQUEMAS HIDRÁULICOS ESQUEMAS HIDRÁULICOS | 79-82 |
|---|--------------|



The operations marked with this symbol are to be undertaken exclusively by an installation technician



The operations marked with this symbol are to be undertaken by the user.

EN ENGLISH

CONTENTS

| | |
|---|-----------|
| Machine identification data..... | 43 |
| 1. General safety rules | 43 |
| 2. Description..... | 44 |
| 2.1. Specifications and composition | 44 |
| 2.2. Machine equipment | 44 |
| 2.3. Mechanical protective devices | 44 |
| 2.4. Electric safety devices | 45 |
| 2.5. Aerial noise..... | 45 |
| 2.6. Vibrations..... | 45 |
| 3. Technical data..... | 45 |
| 3.1. Dimensions and weights..... | 45 |
| 4. Use..... | 45 |
| 4.1. Precautionary measures | 45 |
| 5. Transport..... | 45 |
| 5.1. Packaging | 45 |
| 5.2. Inspection on receipt | 45 |
| 6. Installation | 46 |
| 6.1. Connections to be made by the user..... | 46 |
| 6.1.1. Water supply..... | 46 |
| 6.1.2. Electric supply | 46 |
| 6.2. Connections | 47 |
| 7. Operation | 47 |
| 7.1. Controls | 47 |
| 7.2. Control instruments | 48 |
| 7.3. Starting up | 48 |
| 8. Use..... | 48 |
| 8.1. Preparing coffee | 48 |
| 8.2. Preparing cappuccino..... | 49 |
| 8.3. . Warming a beverage..... | 49 |
| 8.4. Preparing tea, camomile, etc..... | 49 |
| 9. Adjustments and settings of the dose | 49 |
| 9.1. For models DE | 49 |
| 9.1.1. Adjusting the dose | 49 |
| 10. Maintenance..... | 50 |
| 10.1. Daily..... | 50 |
| 10.2. Weekly | 50 |
| 10.3. Periodical | 50 |
| 10.3.1. Renewal of water | 50 |
| 10.3.2. Softener regeneration..... | 51 |
| 11. Stopping the machine..... | 51 |
| 12. Troubleshooting | 51 |

NAME: **Coffee machine, EPOCA series**

MODEL: **DE - CD - S**

VERSIONS: **2 GROUPS**

The label illustrated on the EC Declaration of Conformity of this instruction manual corresponds to the identification label placed on the machine Fig. 2. (Pos. A).

- 1 Manufacturer
- 2 Model and version
- 3 Voltage
- 4 EC conformity mark (if required)
- 5 Serial number
- 6 Boiler data
- 7 Machine total absorption
- 8 Protection level
- 9 Motor power
- 10 Heating element power
- 11 Frequency
- 12 Conformity marks
- 13 Year of manufacture

Symbols



Warning signal. The instructions which refer to this signal must be followed with great care in order to avoid accidents or damage to the machine.

This manual is an integral and essential part of the product and must be delivered to the user. The warnings contained in it must be read carefully, as they supply important indications relating to the safety of installation, use and maintenance. Keep this manual for future reference.

1. GENERAL SAFETY RULES

- Don't leave the packing elements (plastic bags, expanded polystyrene, nails, cardboard, etc.) within the reach of children, as these elements are potential sources or danger.
- Check that the data on the machine corresponds to that of the electrical supply network, before connecting the equipment.
- Adaptors, multiple sockets and /or extensions must not be used.
- In doubt, request an accurate control of the plant by qualified personnel. The electric plant must be provided with the following safety devices:
 - efficient earth connection;
 - section of conductors suitable for absorption capacity
 - efficient earth leakage protection circuit breaker.
- Install the machine on a water repellent surface (laminated, steel, ceramic, etc.) away from heat sources (oven, cooking stove, fireplace, etc.) and in conditions in which the temperature may not go below 5°C. **KEEP WARM.**

- Do not leave the machine exposed to atmospheric agents or place them in damp rooms such as bathrooms.
- Do not obstruct the suction or dispersion grilles and do not cover with cloths, etc.
- Keep the packed machine in a dry place, not exposed to atmospheric agents and in conditions in which the temperature does not go below 5°C. Do not stack more than three items of the same kind. Do not place heavy items on the packaging.
- In an emergency, such as the breaking out of a fire, unusual noise, overheating, etc., take immediate action, disconnecting the power and closing gas and water taps.
- Only use original spare parts in order to avoid compromising the safety and proper functioning of the machine.



Erroneous installation can cause damage to people, animals and things for which the manufacturer cannot be considered responsible

2. DESCRIPTION

The machines in the EPOCA series have been designed to prepare express coffee and hot beverages. A positive-displacement pump inside the machine powers the heater in which the water is heated. By pressing the appropriate buttons, water is supplied to the spouts in the form of hot water or steam, according to needs.

The water to be used for the beverages is supplied directly by the water supply, pressurized by the pump and immediately heated by the steam produced by the boiler.

The machine is composed of a steel carrying structure on which the mechanical and electrical components are fitted. These are completely covered with panels made of painted polyurethane and stainless steel.

The beverages are dispensed at the front of the machine, where all the buttons, control devices and dispensers are to be found.

There is a cup-warming plate on the top of the machine.

2.1. Specifications and composition

| | A | B | C | D | E |
|----|----|----|---|---|---|
| DE | - | ok | 2 | 2 | 1 |
| CD | ok | - | 2 | 2 | 1 |
| S | ok | - | 2 | 2 | 1 |

Legend:

A Semiautomatic system; manual dispensing start and stop.

B Automatic system; electronic control of coffee and hot water doses dispensed.

C N. of coffee dispensing units.

D N. of steam spouts.

E N. of hot water spouts.

On request:

- cup-warmer.

- 1 Steam tap
- 2 Steam spout
- 3 Hot water tap
- 4 Hot water spout
- 5 Coffee dispensing unit
- 6 Coffee dispensing button
- 7 Manual water supply tap
- 8 Level indicator
- 9 Gauge
- 10 Power on-off switch and led
- 11 Switch and boiler resistance engagement light.
- 12 Cup heater switch and indicator

2.2. Machine equipment

| | 2 GROUP |
|-----------------------|---------|
| 1 dose filter holder | 1 |
| 2 dose filter holder | 2 |
| Filters | 3 |
| Blind filter | 1 |
| 1 mt. supply pipe | 1 |
| 1,5 mt. supply pipe | 1 |
| 1,5 mt. drainage pipe | 1 |
| Pipe connections | 1 |
| Doser and presser | 1 |
| Instruction manual | 1 |
| Brush | 1 |
| Wiring diagram | 1 |

2.3. Mechanical protective devices

The machine is equipped with the following protective devices:

- complete panelling protection of all the parts subject to heat and of the steam and hot water supplier;
- cup-warmer plate supplied with a tray to collect spilt liquids;
- work surface provided with grill and tray to collect spilt liquids;
- expansion valve in the hydraulic system and valve on the boiler to avoid overpressure;
- nonreturn valve on the hydraulic system to avoid flowing back to the main supply.

2.4. Electric safety devices

The safety devices provided are:

- 5V low tension push buttons on the DE control key panel;
- thermal protection on the pump motor;
- safe resistance thermal.

2.5. Aerial noise

Noise level in the working place does not usually exceed 70dB(A).

2.6. Vibrations

The machine is supplied with rubber vibration damping feet. In normal working conditions, the machine does not produce vibrations harmful to the operator and the environment.

3. TECHNICAL DATA

3.1. Dimensions and weights (Fig.5)

| | 2 GROUP |
|---------------------------|-------------|
| A mm | 780 |
| B mm | 750 |
| C mm | 560 |
| D mm | 400 |
| H mm | 480 |
| Boiler capacity in liter. | 11 |
| Machine weight kg | 53 |
| Water inlet | 3/8" |
| Ømm drainage | 30 |
| Packaging | |
| Volume cm ³ | 423 |
| Dimensions L x P x H mm | 910x670x720 |
| Gross weight kg | 67 |



You'll find all the technical data on electric connection, on the machine identification label Fig. 1.

4. USE

The machine have been designed, manufactured and protected to be used to make express coffee and hot beverages (tea, cappuccino, etc.). Any other use is to be considered unsuitable and therefore dangerous.



The manufacturer cannot be held responsible for any damage caused to people or things due to unsuitable, erroneous or irrational use of the machine.

The operator must always follow the indications contained in this manual. In the case of a failure or if the machine is not working properly, switch it off and do not attempt any direct repair. Refer exclusively to a service centre.

The user must not:

- touch the hot surfaces and dispensing areas;
- place liquids containers on the machine;
- put his hands under the spouts during use;
- transport the machine or carry out maintenance operations when the plug is connected or when the machine is hot;
- wash the machine with water or steam jet;
- dip completely or partially the machine in water;
- use the machine if the cable is damaged;
- touch the machine when his hands or feet are wet or damp;
- use the machine when there are children in its proximity;
- allow the machine to be used by children or unfit people;
- obstruct the suction or dispersal grilles with cloth or any other thing;
- do not use the machine when wet or very damp.

4.1. precautionary measures

This machine may only be used with foodstuffs. It cannot be used for heating liquids or grinding any other kind of product that could damage and pollute it.



The manufacturer cannot be held responsible for damage to people or things caused by unsuitable, erroneous or irrational use.

5. TRANSPORT

5.1. Packaging

The machine is delivered in a strong cardboard box with internal protection.

The packaging bears symbols which must be observed during handling and stocking of the item.



Always keep the package in a vertical position during transport. Do not turn it over or lay it on its side and avoid bumping and exposure to atmospheric agents.

5.2. Inspection on receipt

Check that the machine received corresponds to the one indicated on the delivery note, including any accessories.

Check that it has not been damaged during transport and, if so, inform the forwarder and our customer service office immediately.



The packing elements (plastic bags, expanded polystyrene, nails, cardboard, etc.) must not be left within reach of children as they are potential sources of danger.



6. INSTALLATION

The appliance is only to be installed in locations where use and maintenance is restricted to trained personnel.

The machines are fitted with height adjustable feet. The support surface shall be levelled, dry, smooth, steady and stable and at such a height that the cup-warming surface is at over 150 cm from ground. Do not use water jets or install where water jets are used.

In order to guarantee normal operation, the machine must be installed in areas that the environmental temperature is between +5°C ÷ +32°C and humidity of not over 70%.

It does not need to be anchored to the surface and it does not require any technical operations to dampen vibrations in order to operate properly.

It is recommended to leave the area around the machine free to facilitate its use and the performance of any maintenance operations.

If the machine is wet or very damp, wait until it is completely dry before installing or using it. It is always necessary to request an accurate control to qualified service people in order to find any possible damage to the electric components.

Reserve an area near the machine for the installation of the coffee grinding and dosage machine (see relevant documentation).

The machine is usually equipped with a water softener, type DP2 or DP4, which must be connected by the user in compliance with the laws in force. Should a different softener be installed, refer to the documentation of the relevant product.

A dreg drawer should be fitted by the installer.



6.1. Connections to be made by the user.



Hook-up must be carried out by qualified personnel in full accordance with federal, state and local regulations.

6.1.1. Water supply (Fig.6)



This equipment is to be installed to comply with the applicable federal, state or local plumbing codes.

Connections must be installed close to the machine.

- Water drainage pipe 1, having a minimum internal diameter of 30 mm, equipped with a water-trap accessible for inspection.
- Water supply pipe 2, with a 3/8"G cut-off tap.



Make sure that the maximum supply pressure does not exceed 6.5 bar; otherwise, install a pressure reducer.



6.1.2. Electric supply

The machine is supplied ready for connection according to the required electrical specifications.

Before connecting the machine ensure that the plate details comply with those of the electric distribution network.

The electrical connection cable must be directly connected to the connection provided according to current legislation. Ensure that the earthing system is efficient and in compliance with current legal requirements.

The earthing system and the lightning protection system must be realized in accordance with the provisions of current legislation.

For the supply network use a cable in compliance with standards with protective conductor (earthing wire).

For three-phase power use a cable with 5 conductors (3 phases + neutral + earth).

For single phase power supply use a cable with 3 conductors (phase + neutral + earth).

In both cases it is necessary to provide an automatic differential switch (Fig. 6) at the start of the power cable, complete with magnetic release elements in accordance with the identification plate details (Fig. 1). The contacts must have an opening of equal or over 3 mm and with dispersed current protection of 30 mA.

Remember that each machine must be fitted with its own safety elements.



WARNING:

Should the power supply cable be damaged it is to be replaced by the manufacturer or by its technical assistance service or by person with equivalent qualification, in order to prevent any risks.



6.2. Connections

- Place the machine on the horizontal surface previously prepared.

Before connecting, thoroughly wash the mains water pipes:

- Leave the water supply taps running at full pressure for several minutes.
- Connect to the mains water supply.
- Connect the machine to the socket.

Thoroughly wash all the water pipes of the machine:

- Leave the water supply taps running at full pressure.
- Switch on main switch 1: wait until the boiler fills up to the level set.
- Switch on main switch 2 to begin heating the water in the boiler.
- Operate each unit in order to allow the water to escape for about one minute; repeat the operation twice.
- Deliver steam from the steam jets for about one minute.
- Deliver hot water for about one minute; repeat the operation twice.
- Switch off switches 1 and 2.
- Empty the water from the boiler: see point 10.3



IMPORTANT

Should the machine not deliver water for over 24 hours, wash the internal components before beginning work, repeating the operations as described above



ATTENTION

Please be informed that in order to avoid pressure falls during the boiler filling we fitted into the filling solenoid valve a restriction Ø 1.25 mm.

If, during the installation, the machine get in security mode (the on/off selection on the touch pad will flash) reset the machine using the main switch.

7. OPERATION

7.1. Controls Fig.7

1 Main switch.

Two-position switch with led.

Turn on the switch, led on, the machine is turned (apart from the boiler) and the pump is turned on to fill the boiler;

2 Boiler resistance switch.

Two-position switch with led.

On activating the switch, the led comes on, and power is supplied to the resistance for the boiler water.

3 Coffee dispensing button (mod. CD).

Press the button for a second, led on, release the button; coffee is continuously dispensed.

Press the button for a second, led off, release button; continuous dispensing of coffee ceases.

4 Coffee dispenser switch (mod. S)

On pressing the button, continuous coffee dispensing begins and the led comes on.

On re-pressing the switch, the coffee delivery stops and the led goes out.

5 Electronic coffee delivery button panel.(mod. DE).

Five buttons with relative led:

A Press the button for a second, led on, release button; a small coffee is dispensed.

The led turns off and dispensing ceases.

B Press the button for a second, led on, release the button; a big cup of coffee is dispensed.

The led turns off and dispensing ceases.

C Press the button for a second, led on, release the button; two small coffees are dispensed from the same unit.

The led turns off and dispensing ceases.

D Press the button for a second, led on, release the button; two big cups of coffee are dispensed from the same unit.

The led turns off and dispensing ceases.

E Press the button for a second, led on, release the button; coffee is continuously dispensed.

Press the button for a second, led off, release button; continuous dispensing of coffee ceases.

To interrupt dispensing taking place by pressing **A-B-C-D**, hold button **E** down until the relative led turns off.

6 Hot water supply tap (mod. CD).

Tap: turn in an anticlockwise direction to open and clockwise to close.

7 Steam supply handwheel.

Tap: turn in an anticlockwise direction to open and clockwise to close.

8 Supplementary manual water supply tap positioned under the cup-stand grille and normally kept turned off.

Turn on the tap to fill the boiler and turn it off when the correct level is reached.

7.2. Control instruments (Fig.7)

9 Gauge with mobile needle on a fixed dial with a double scale.

Visual control of the pump (lower manometer) and of the boiler pressure (upper manometer) (mod. E-S).

10 Minimum and maximum water level indicator .

Visual control of water level in boiler (green Led).

11 Cup-heater switch (optional).

Two-position switch with led.

By turning on the switch (led on), the cup heating resistance is power supplied.



7.3. Starting up

Model S

- Turn on the water supply tap 2 Fig.6.
- Turn the main switch 1; the pump is activated, filling the boiler.
- When the level has been reached the pump stops, then activate switch 2 to begin heating the water in the boiler then turn each one until water begins to flow from them.
- Wait for the machine to reach its working pressure, and to reach the correct thermal balance.

Model DE - CD

- Turn on the water supply tap 2 Fig.6.
- Turn on main switch 1 and resistance switch 2. The pump for boiler filling will activate (red led on level indicator 10).
- Only after reaching the level (green led on level indicator 10) the resistances for water heating in the boiler are powered, then activate every single group until water comes out.
- During the heating phase the leds of the keys switch on in sequence from left to right until the working pressure is reached.

Only when the rated pressure is reached it is possible to adjust the doses for DE model.



Warning! This sequence will be repeated at every switching on.



8. USE

The machine has a top shelf on which the cups are kept and heated, ready for use.

This is very important to obtain good coffee as the pre-warmed cup stops the coffee from growing cold too quickly.

8.1. Preparing coffee

- Unclamp the filter-holder from the dispensing unit and knock any grouts out into the drawer especially provided for this purpose, taking care not to damage the rim of the filter.
- Use the filter for 1 or 2 coffees, according to need.
- Fill the filter with the measure of coffee, level it off and press it down gently with the presser.
- Remove any ground coffee that has stuck to the rim of the filter while pressing.



If ground coffee is left on the rim of the filter, a leaktight seal is not ensured, with consequent leaking of water and coffee grounds.

- Lock the filter-holder into the dispensing unit firmly to obtain a leaktight seal.
- Place the cups under the spouts and start pouring using control 3 - 4 or button panel 5 according to model (Fig.7).
- When the coffee has been poured, leave the filter-holder attached to the dispensing unit until the next coffee is required.



When pouring, beware of the hot parts of the machine, especially the coffee dispensing units, the steam and hot water spouts. Do not put your hands for any reason under the units and the spouts when they are operating.

The grinding of the coffee beans is of fundamental importance to the making of good coffee, and the granular texture of the resulting grounds should be such that it takes 25-30 seconds to produce the beverage. If the coffee is ground too coarsely the coffee will be pale in colour and weak in flavour, with only a very small amount of white cream, and if the grounds are too fine, the coffee will be dark with no cream. Good coffee can only be made if the beans are freshly and uniformly ground (only possible when the blades of the coffee grinder are sharp) and are then measured out into the correct quantities (roughly 6 grams per measure).

The importance of freshly ground coffee beans is due to the fact that once ground, they rapidly lose their aromatic qualities, and fats present in the beans go rancid.

8.2. Preparing cappuccino (Fig.8)

- Make cup of cappuccino with the express coffee.
- Use a high and narrow jug, half-filled with milk.
- Place the jug under the spout so that the nozzle touches the bottom.
- Turn on the steam tap and lower the jug so that the nozzle is almost at the surface of the milk.
- Continuously move the jug up and down so that the nozzle moves in and out of the milk, causing it to froth.
- Turn off the steam tap and pour the milk into the cup.



Immediately after carrying out this operation, clean the spout with a sponge or a clean cloth so that the milk does not dry on it. Be careful as the spout is hot and may burn your hand.

8.3. Heating a beverage

- Immerse the steam spout into the liquid to be heated.
- Gradually turn on the steam tap 7 Fig.7; the steam that bursts in the liquid heats it to the desired temperature.
- Turn off the steam tap when the desired temperature has been reached.



Immediately after carrying out this operation, clean the spout with a sponge or clean cloth. Be careful as the spout is hot and may burn your hand.

8.4. Preparing tea, camomile, etc.

- Place the jug under the hot water spout and turn the water tap 6 (Fig.7). When the desired quantity has been obtained, turn off the tap.
- Add the beverage desired.

When purified water is used, these beverages often assume a darker colour.

Should the user prefer a lighter coloured drink, draw fresh water from an ordinary tap and proceed with the heating phase as described in point 8.3.

9. ADJUSTMENT AND SETTING OF THE DOSE (where available)

9.1. Models DE

It is possible to adjust the dose of coffee dispensed DE models.

9.1.1. Adjusting the dose

The coffee dose adjustments are made by acting on the group keyboards with machine at rated pressure.

- 1 Press the button **E** on any button panel and hold it down for 8-10 seconds until water stops flowing from the dispensing unit and the led of the continuous button on the first button panel on the left begins flashing.
- 2 It is necessary to act as to make 1 or 2 cups in order to reach the correct coffee amount adjustment in the cup.
- 3 Put the filter-holder (with ground coffee) on the left unit and the cup under the spout.
- 4 Operate the selected button (i.e. button **A** for one small cup).
- 5 Once the required coffee amount in the cup has been reached, press the stop button **E**. Coffee will stop pouring and the microprocessor will store the dose.
- 6 Press the continuous button **E** again; the led will go out and the machine will store the new quantity.
- 7 Make the coffee and check the cup amount in order to check that programming is correct.

If some doses have to be changed (**B-C-D**), once at point 5 repeat the instructions in points 3-4-5 for each dose, remembering to use the filter-holder with relevant filter and freshly ground coffee.

Then carry out point 6 and repeat point 7 to check all changed doses.

If all units are to be programmed with the same doses, the selection of coffee doses is finished. If the dosage of another unit is to be changed (1-2-3-4 doses), proceed as indicated in the above-mentioned point 1-7, using only the button panel of the selected unit.



10. MAINTENANCE

Maintenance operations have to be carried out when the machine is off and cold and the plug is disconnected. Some particular operations have to be effected when the machine is operating.



Do not clean the machine by using metal or abrasive devices, such as steel wool, metal brushes, needles, etc. or general detergents (alcohol, solvents, etc.)

When necessary, use special detergents for coffee machines that can be bought in specialized service centres.

10.1. Daily (Fig.9)

Use a clean cloth or sponge that does not leave hairs or fluff (preferably cotton or linen).

- Carefully clean the outside surface, following the grain of the satin finish on the parts in stainless steel.
- Clean the steam and hot water spouts, check that the nozzles are not encrusted (if they become encrusted, be careful not to deform or damage them).
- Clean the spray units and the seals under the casing of the delivery units using the special brush supplied
- Remove the filter-holders of the machine and remove the filters and the clamp which secures the filter, use a brush to remove any coffee deposits and rinse with hot water in order to dissolve any grease deposits.

10.2. Weekly



Operations to be carried out with the machine operative and under pressure.

- Place the supplied blind filter in the filter-holder, put in a spoonful of detergent in powder for coffee machines and fit the filter-holder in the unit to be cleaned.
- Press the coffee dispensing button and draw water for approx. 30 seconds.
- Stop and start dispensing several times until clean water comes out of the discharge unit tube.
- Remove the filter-holder, take out the blind filter and insert a normal one. Replace the filter-holder on the unit and rinse by drawing water several times.
- Make a coffee to eliminate any unpleasant taste.

Cleaning the filters and delivery heads (Fig.9)

Operation to be carried out when the machine is off and cold.

- Prepare a solution of 4 sachets of detergent powder Code **69000124** dissolved in a litre of boiling water in a stainless steel, plastic or glass recipient (**NOT ALUMINIUM OR IRON**).
- Remove the filters and immerse them with the filter holders in the prepared solution, leaving them for at least 10/20 minutes (all night is better).
- Remove them from the container and rinse them thoroughly in running water.

Tank cleaning (Fig.10)

- Remove the cup-stand grille 1 (Fig.10) and clean.
- Check and clean the drainage sump 3 (Fig.11), removing any sludge with the help of a spoon.

10.3. Periodical maintenance



Operation to be carried out with the machine under pressure.

- Discharge the water from the boiler (about four litres) with hot water delivery switch 6.
- Wait until the machine has returned to heat equilibrium before reuse.



10.3.1. Renewal of water in the boiler

To be carried out only by qualified personnel.

- Turn off the machine and wait for the pressure in the boiler to diminish (gauge needle on "0").
- Using a spanner firmly hold 1 the outlet pipe 2 Fig.11 situated about the drainage sump while loosening the hexagonal sealing screw 4 by 3 turns at the most.
- Drain off the water and tighten the screw 4.
- Refill the boiler (paragraph 7.3.).

10.3.2. Regeneration

Softener DP2 - DP4

Regenerate the water softener within the time-limits specified for the softener as follows:

DP2

nr.1 regeneration per month for 500 coffees/day;
nr.2 regenerations per month (once a fortnight) for 1000 coffees/day.

DP4

nr.1 regeneration per month for 1000 coffees/day;
nr.2 regenerations per month (once a fortnight) for 2000 coffees/day.

This table has been drawn up according to a water hardness of 25 degrees calculated on the French scale.

See the documentation included with the softener for the instructions for use.

11. STOPPING THE MACHINE

A - Temporary stop

- Carry out cleaning and maintenance operations.
- Wind up the cable and fasten it to the machine with sticky tape.
- Cover the machine and place it in a dry room. Do not leave it exposed to atmospheric agents and do not allow it to be touched by children or unfit persons.

To disconnect from the main power supply, consult qualified personnel.

B - Definitive stop

- Besides carrying out the operations necessary for a temporary stop, cut off the cable, pack the machine in cardboard, polystyrene or other packing material and consign it to firms authorized for its disposal or to second-hand goods dealers.

12. PROBLEMS AND REMEDIES



Check operations to be carried out by the user with the plug disconnected.

For any type of problem or inconvenience not specifically indicated, disconnect the plug and contact our service centre without attempting any direct repairs.

A) The machine does not start:

- *check that the plug is connected;*
- *In case of power failure wait for the power to return and check if the earth leakage protection circuit breaker or the main switch is on;*
- *check the condition of the plug and the supply cable; if damaged have them replaced by qualified personnel.*

B) There is water under the machine:

- *check that the drainage tray is not obstructed.*

C) Slow dispensing:

- *check that the filters and delivery heads are clean;*
- *check that the coffee is not too finely ground.*

D) Irregular steam delivery:

- *check that the nozzles are not obstructed.*